

end extender

center extender

tab

tab

second embossment

CENTER STANDARD EXTENDER

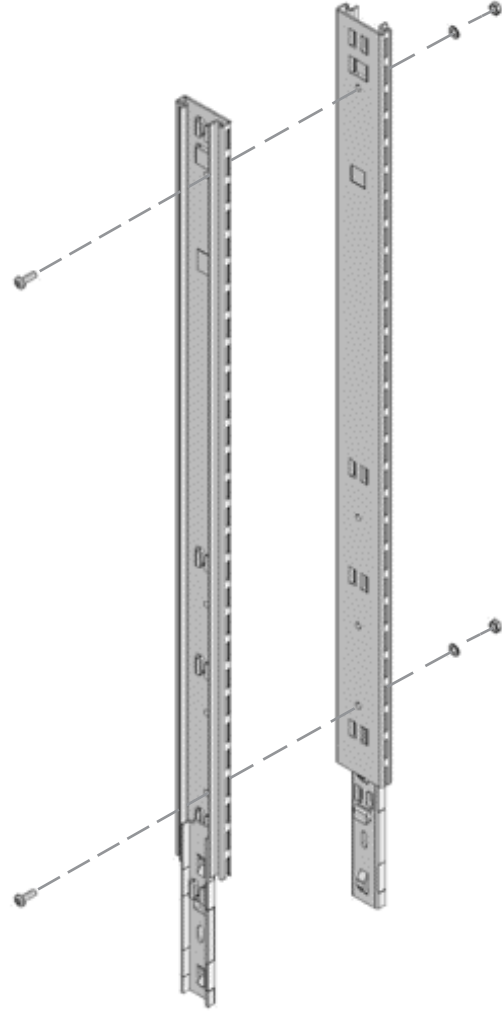

To assemble a center standard extender take two (2) end extenders put them back-to-back and secure with two (2) 1/4-20 x 3/4 screws (one top and one bottom as pictured), two (2) 1/4 washers, and two (2) 1/4-20 hexnut.

1

Remove the top cap from the existing module and slide the extender inside the upright, then hook the tab on the extender over the second embossment on the standard. When assembled correctly the extender standard will rest directly on top of the existing standard.

