



MIDWEST
RETAIL SERVICES, Inc

Midwest Retail Services, Inc.

800-576-7577

www.midwestretailservices.com

ETALEX™
Member of SJM group

**S-SERIES
SHELVING**



THE S SERIES

The “S” Series really delivers by combining a multi-part post with unbeatable rigidity. Available with either high base 7” or low base with detachable base shelf and our ingenious locking assembly. As a result, it costs a lot less for you to change your aisle layouts. The backs are made of solid or perforated masonite and are available in the most popular colours. From dollar stores to supermarkets, it’s an excellent choice. The best store shelves systems for your business.

TECHNICAL SPECIFICATIONS

POST HEIGHT: 48”- 120” (IN INCREMENTS OF 6”)

BASE SHELF: 6”- 30” DEEP (IN INCREMENTS OF 2”)

WIDTH: 24”- 48” (IN INCREMENTS OF 6”)

**BASE SHELF HEIGHT:
5” H. (FROM FLOOR TO THE TOP OF THE LOW BASE SHELF)
7 1/4” H. (FROM FLOOR TO THE TOP OF THE HIGH BASE SHELF)**

REAR BACK OPTIONS: MASONITE (PLAIN OR PERFORATED), WIRE MESH & SLATWALL

OPTIONAL BACKS



PERFORATED MASONITE



PLAIN MASONITE



SLATWALL

BASE SHELF OPTIONS



OPEN KICKPLATE



CLOSED KICKPLATE

STRUCTURE - S SERIES

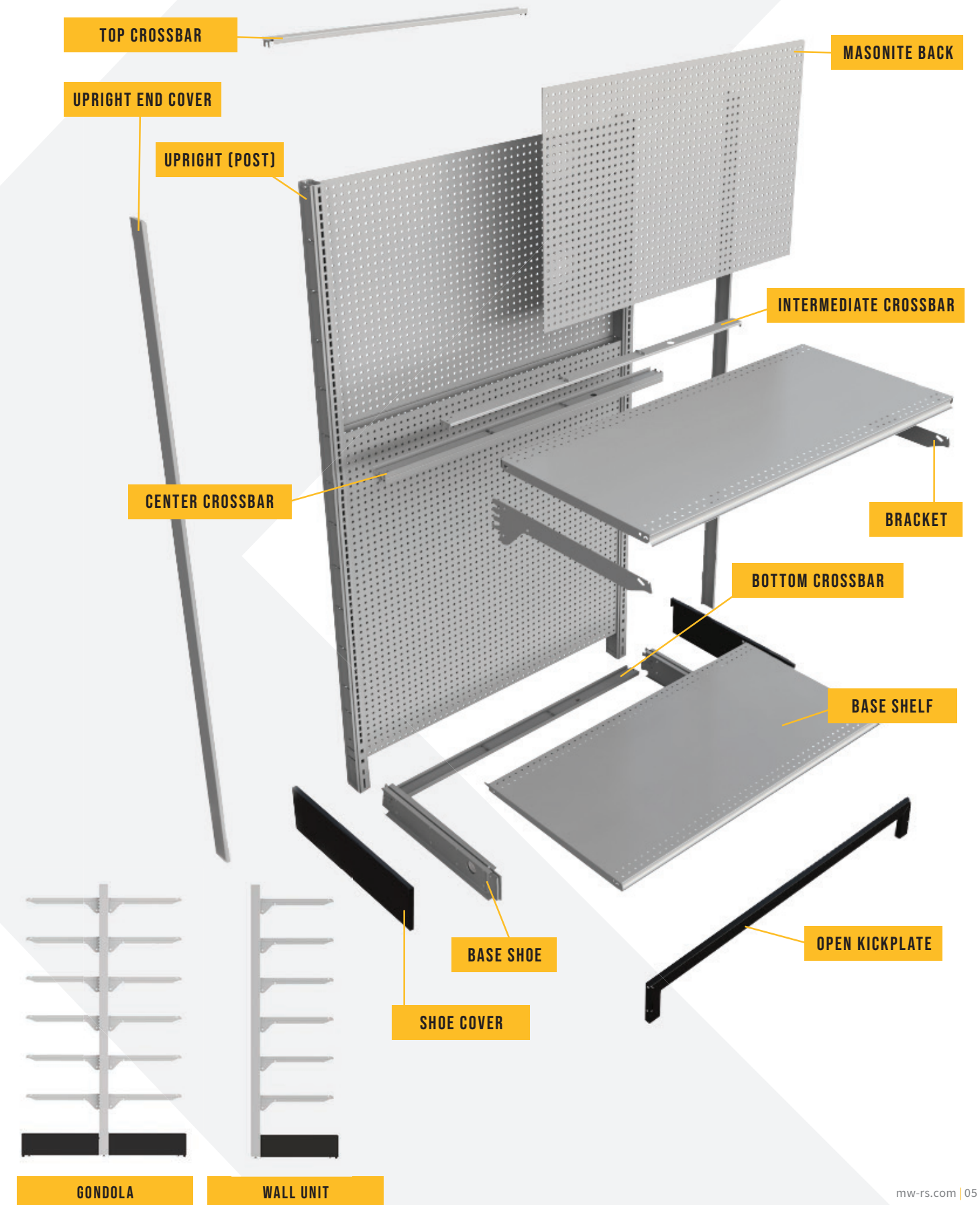

POST AND SHOE

HD POST

ITEM: 2010453XX
WIDTH: 2 7/8" X 1 1/4"

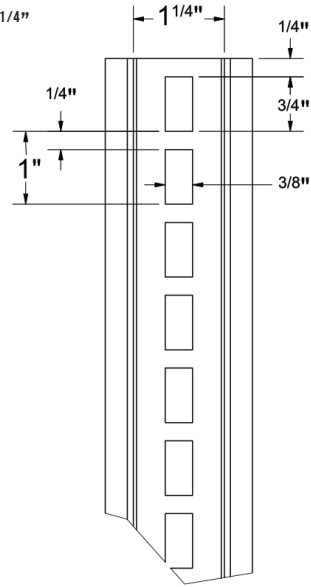

UPRIGHT END COVER

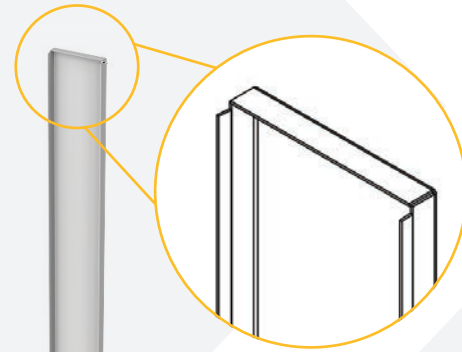
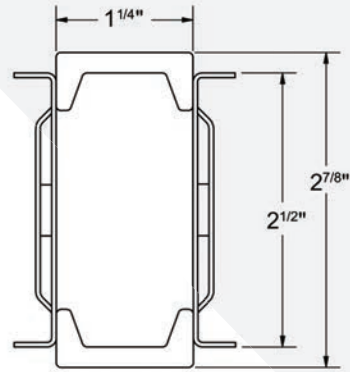

IN INCREMENTS OF 6"
36" TO 96"
+
108"
ITEM: 201010XX

END CAP REQUIRED ONLY ON END POLES.

SHOE

ITEM: 2040101XX ITEM: 2040100XX
HEIGHT: 4 3/8" HEIGHT: 5 7/8"

AUTO-BLOCKING SAFETY PIN

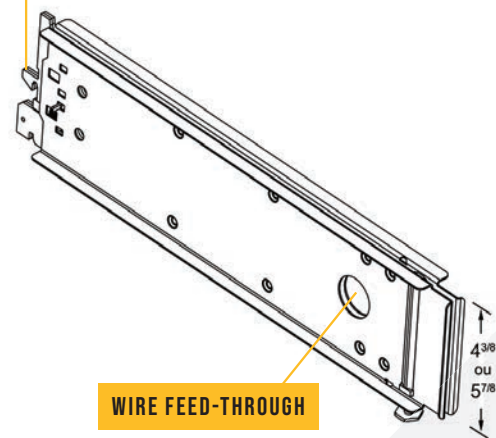

WIRE FEED-THROUGH

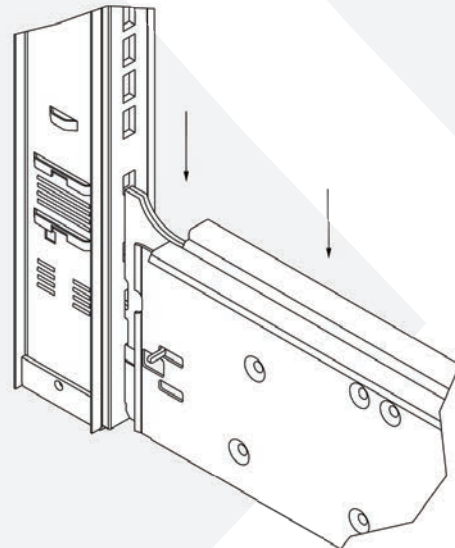
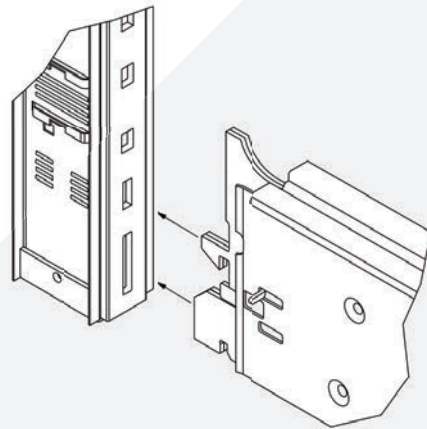

REMOVABLE SHOE WITH AUTO-BLOCKING SAFETY PIN AND WIRE FEED.

SHOE AND KICK PLATE

SHOE COVER

ITEM: 2040410XX RIGHT / 2040411XX LEFT
HEIGHT: 6 3/4" (BOTTOM)
ITEM: 2040400XX RIGHT / 2040401XX LEFT
HEIGHT: 8 1/4" (TOP)

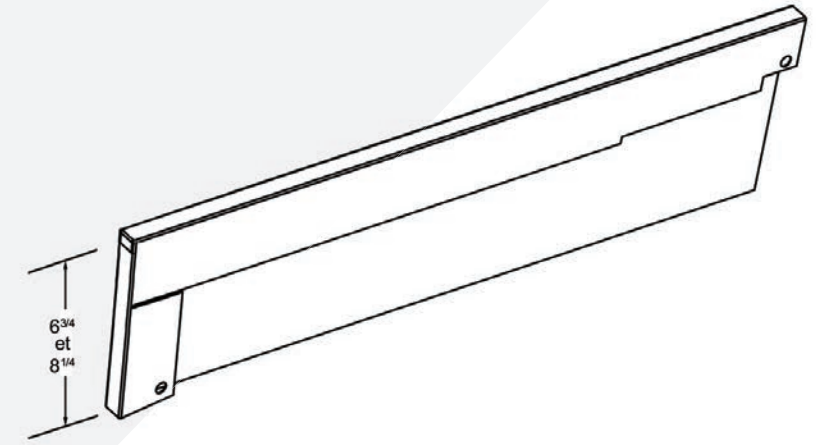

OPEN KICK PLATE

ITEM: 2050151XX = 6 3/4" (BOTTOM) / 2050150XX = 8 1/4" (TOP)

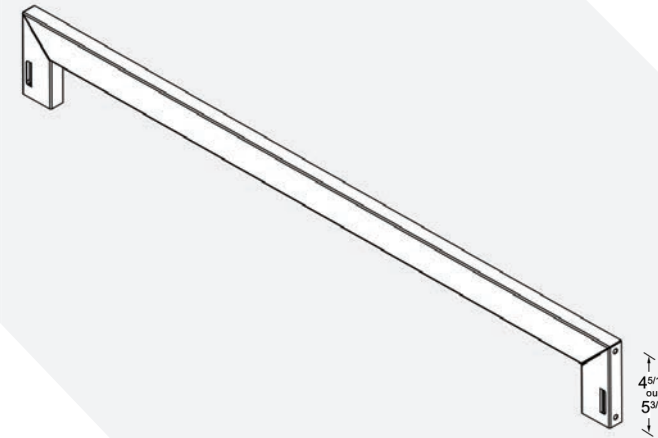

OPEN KICK PLATE FOR EASY CLEANING UNDER THE SHELF.

CLOSED KICK PLATE

ITEM: 2050101XX = 6 3/4" (BOTTOM) / 2050100XX = 8 1/4" (TOP)

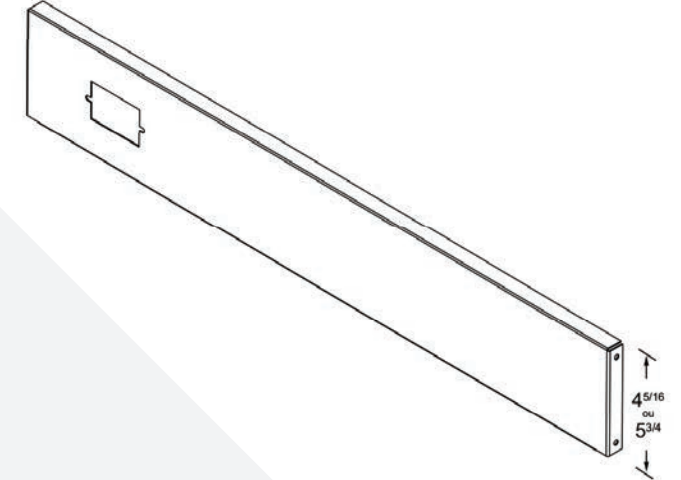

CLOSED KICK PLATE (WITH HOLE FOR ELECTRIC PLUG).

SHELVES

BRACKETS

BASE SHELF

ITEM: 20302PPLL

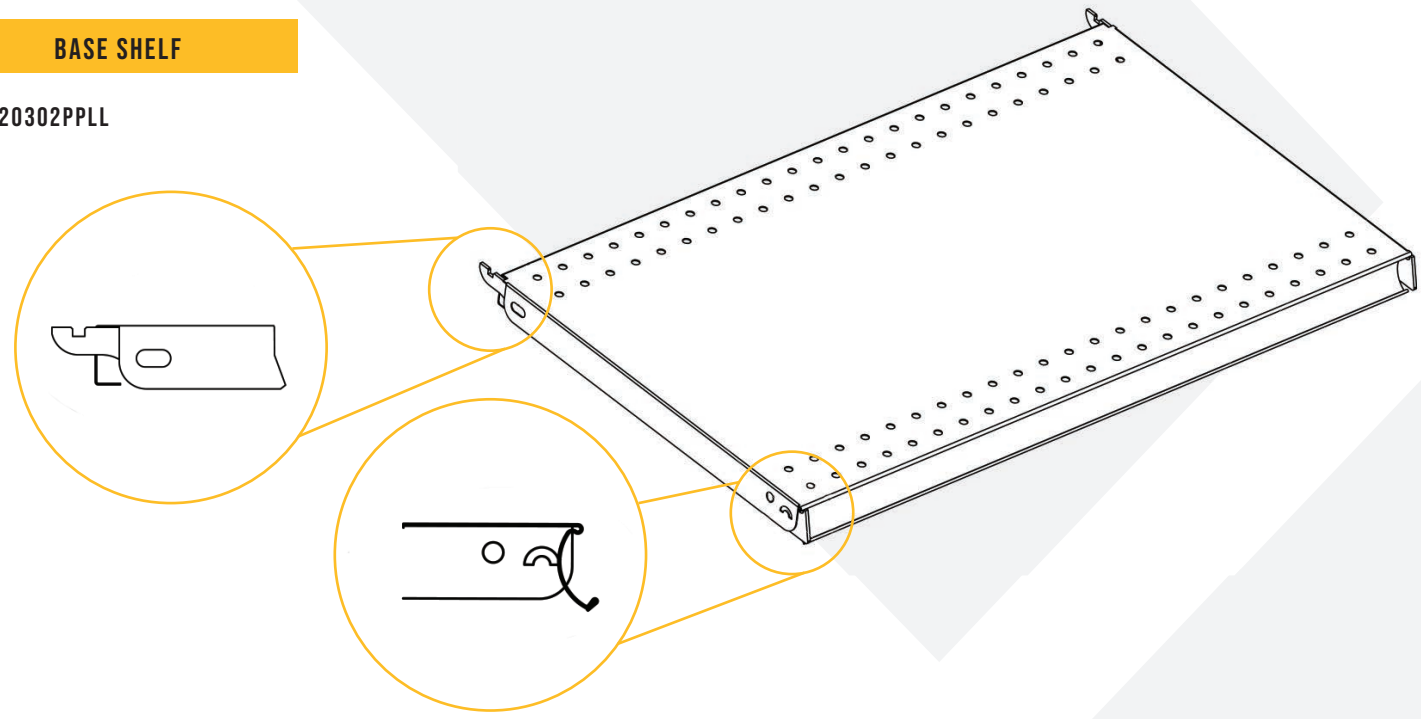

COMES WITH WELDED BACK FASTENERS. STANDARD 1 1/4" LABEL HOLDER AND FOUR ROWS OF HOLES FOR DIVIDERS.

UPPER SHELF

ITEM: 00301PPLL

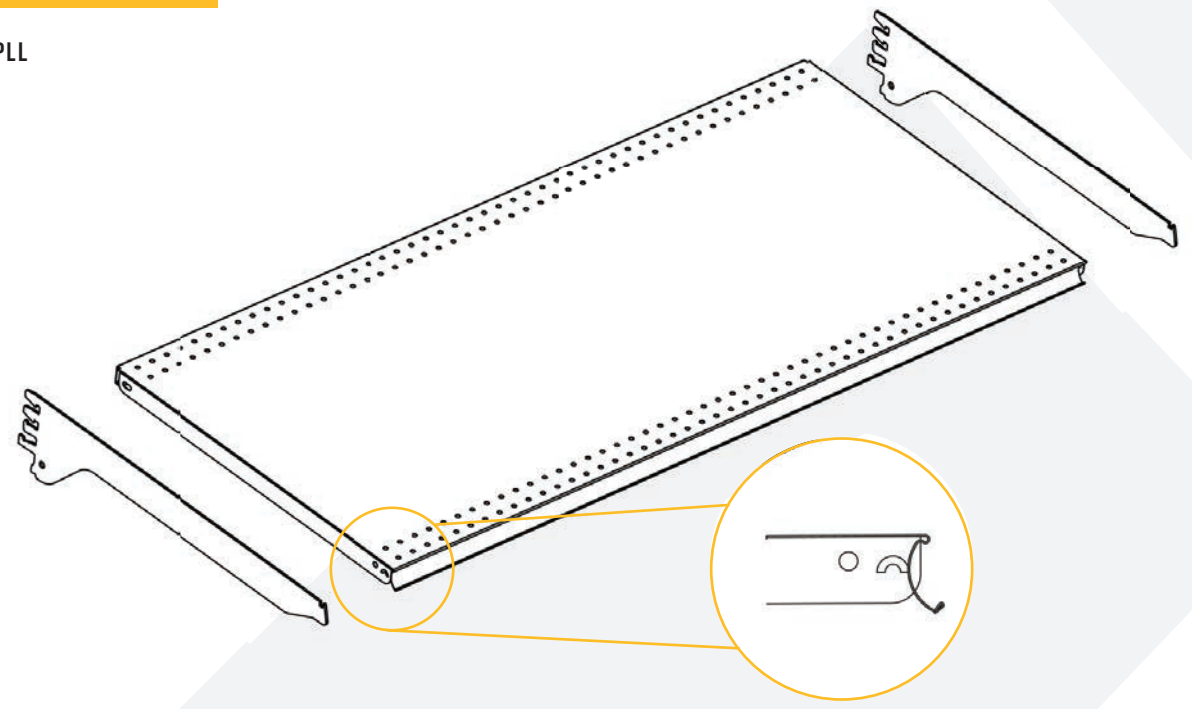

BRACKET NOT INCLUDED. STANDARD 1 1/4" LABEL HOLDER. OPTION WITH WELDED SUPPORTS AVAILABLE.

		2 POSITION BRACKET				
		LENGTH	PRODUCT CODE	THICKNESS		
11 GA (0.121")	LENGTH	6"	210010006	0.121"		
		8"	210010008	0.121"		
		12"	210010012	0.121"		
		3 POSITION BRACKET				
12 GA (0.099")	LENGTH - 3/32"	10"	210020010	0.099"		
		12"	210020012	0.099"		
		14"	210020014	0.099"		
		3 POSITION BRACKET				
12 GA (0.099")	LENGTH + 1/16"	16"	210020016	0.099"		
		18"	210020018	0.099"		
		20"	210020020	0.121"		
		22"	210020022	0.121"		
		24"	210020024	0.121"		
		26"	210020026	0.121"		
		1 POSITION HD BRACKET				
		LENGTH	PRODUCT CODE	THICKNESS		
11 GA (0.121")	SUPP-210050022-36X	22"	210050022	0.121"		
		24"	210050024	0.121"		
		26"	210050026	0.121"		
	REV	210050028RA-36X	A	28"	210050028	0.121"
		210050030RA-36X	A	30"	210050030	0.121"
		210050036RA-28X	A	36"	210050036	0.121"

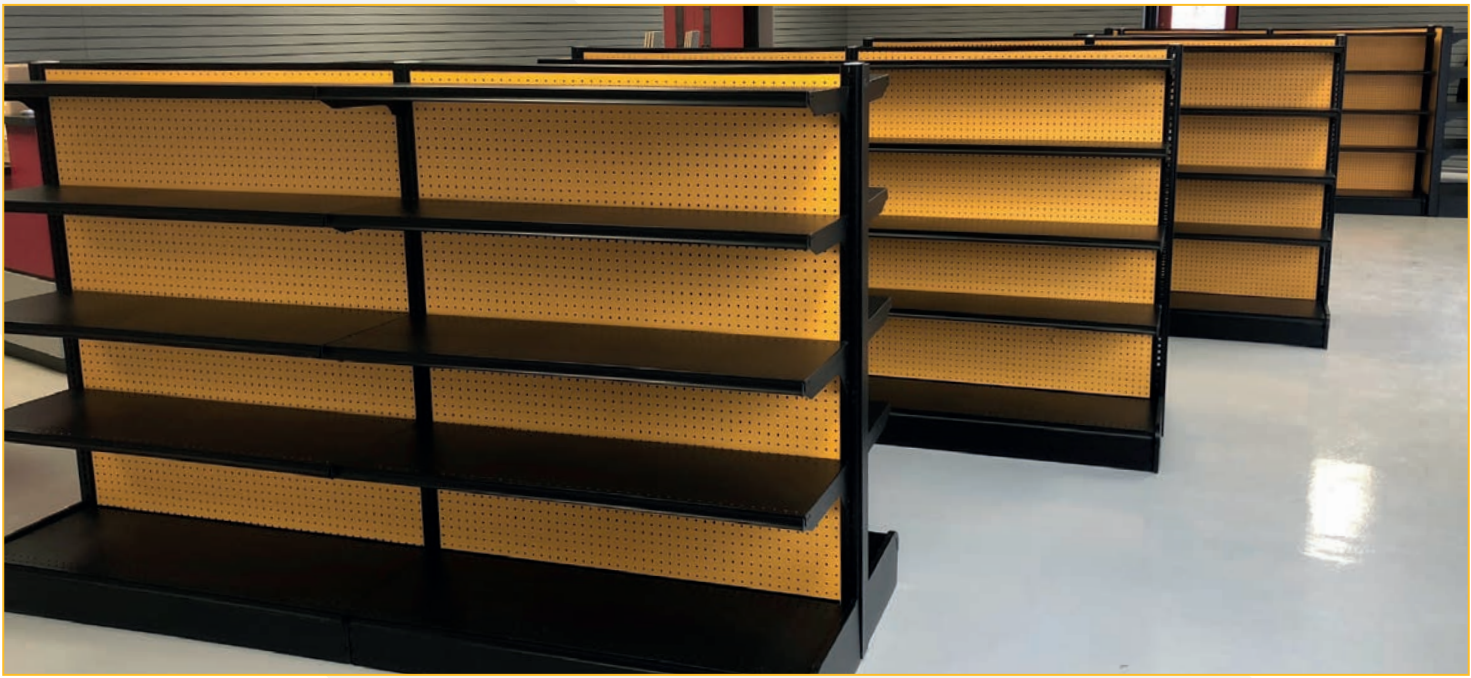

ASSEMBLY

PLAIN MASONITE BACK

ITEM: PLB05 HH LL
THICKNESS = 1/4"

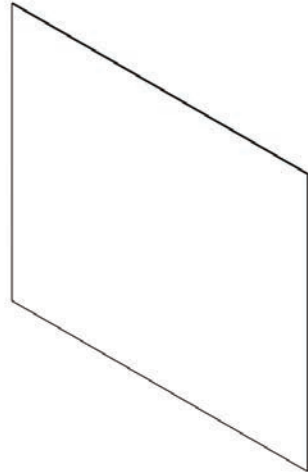

PERFORATED MASONITE BACK

ITEM: PEB05 HH LL
THICKNESS = 1/4"

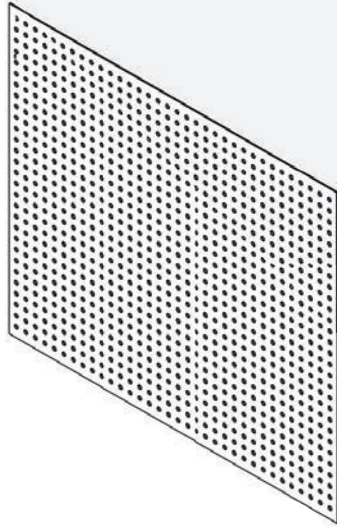

SLATWALL BACK

HEIGHT = NOMINAL - 65/8"
LENGTH = NOMINAL - 17/16"
THICKNESS = 3/4"

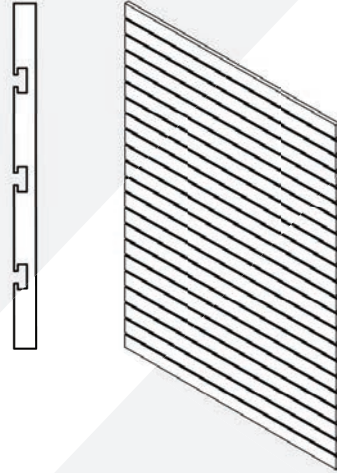

LENGTH: IN INCREMENTS OF 6" / 24" À 48"
HEIGHT: IN INCREMENTS OF 6" / 36" À 96" + 108", 120"

GRID OF THE MASONITE CHART

NOMINAL HEIGHT POST IN INCHES	NOMINAL HEIGHT 1 ST BACK IN INCHES	NOMINAL HEIGHT 2 ND BACK IN INCHES	TOP CROSS-BAR QUANTITY NEEDED	INTERMEDIATE CROSS-BAR QUANTITY NEEDED
36"	30"	-	-	1
42"	36"	-	-	1
48"	42"	-	-	1
54"	48"	-	-	1
60"	54"	-	-	1
66"	60"	-	-	1
72"	66"	-	-	1
78"	48"	24"	1	1
84"	48"	30"	1	1
90"	48"	36"	1	1
96"	48"	42"	1	2
108"	48"	54"	1	2
120"	48"	60"	1	2

HEIGHT = NOMINAL - 1/8" / LENGTH = NOMINAL - 17/16" / THICKNESS = 1/4"

ASSEMBLY

CROSS-BARS LENGTH: 24", 30", 36", 42", 48"	FOR MASONITE BACK	FOR SLATWALL BACK
TOP CROSS-BAR CLOSES THE TOP OF A SECTION	 ITEM: 2070100XX	 ITEM: 2070105XX
INTERMEDIATE CROSS-BAR TO SUPPORT THE BACK (HOLES FOR WIRING)	 ITEM: 2070400XX	 ITEM: 2070420XX
CENTER CROSS-BAR FOR BACK SECTION MASONITE ONLY. SERVES AS A SEAL BETWEEN THE PANELS	 ITEM: 2070300XX	
INFERIOR CROSS-BAR SUPPORTS BACK AT THE BASE	 ITEM: 2070200XX	 ITEM: 2070230XX

ASSEMBLY

«T» CAP

3 PIECES (INCLUDES # 1, 2 AND 3)

FOR HEIGHT OF 72"
AND/OR FOR HEAVY USAGE

LENGTH :
24", 30", 36", 42", 48"

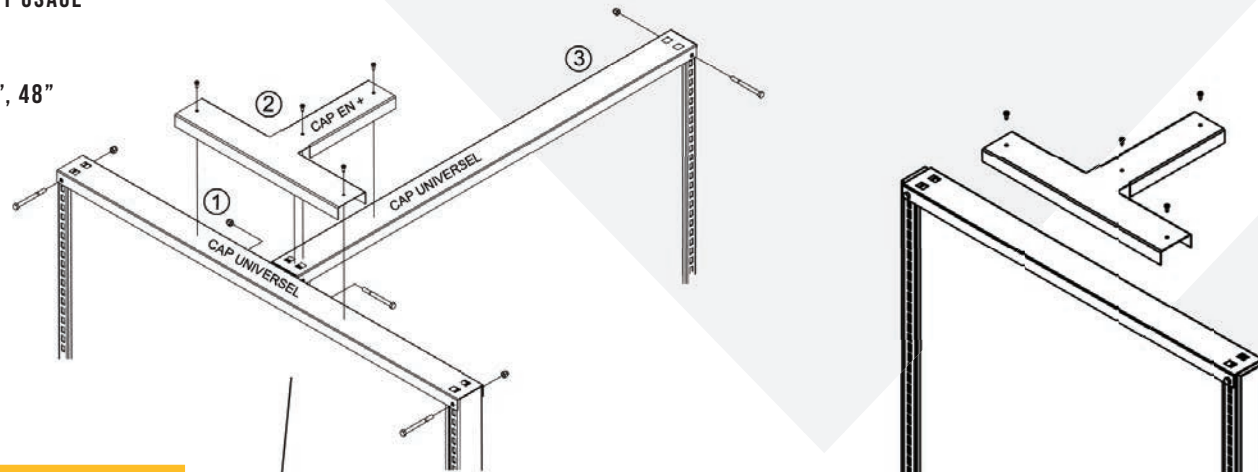

FINISHING CAP

2 PIECES (INCLUDES # 1, AND 4)

FOR HEIGHT OF 72"
AND/OR FOR LIGHT USAGE

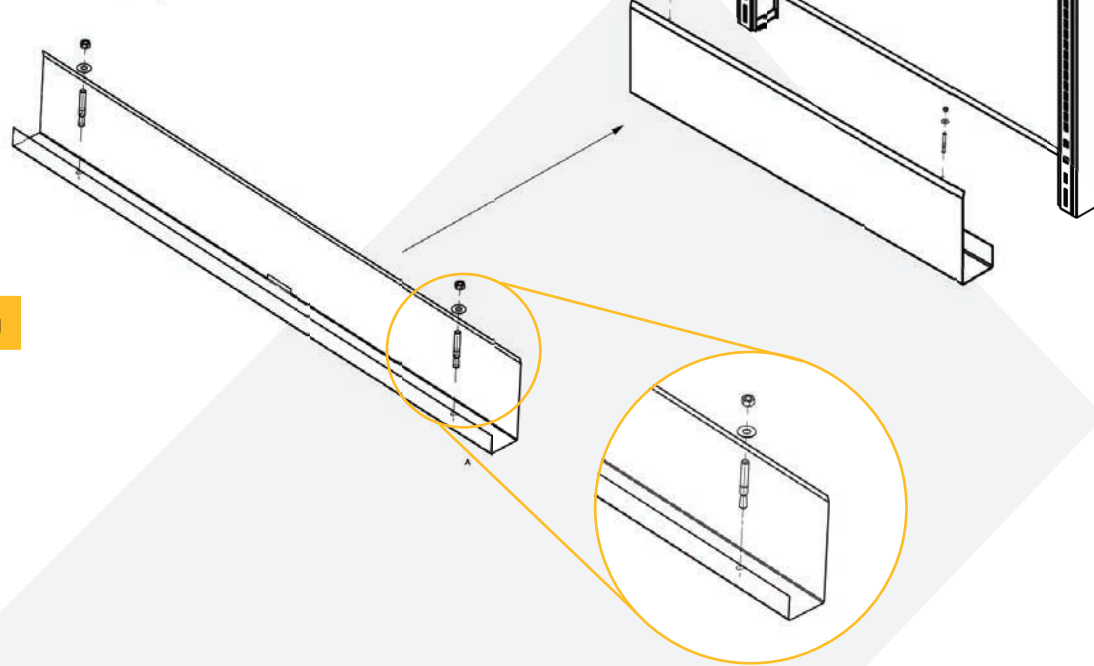

FLOOR RETAINING BASEBOARD

FOR END OF WALL UNITS
0050810XX

LENGTH :
24", 30", 36", 42", 48"

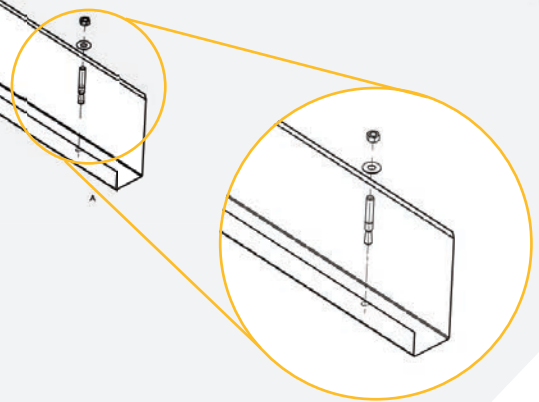

ASSEMBLY

WALL ANCHORING

INSTALL THE WALL ANCHOR BRACKET AT THE TOP OF EACH POST. INSERT THE TOOTH OF THE ANCHOR IN THE FIRST SLOT FROM THE BACK BY TURNING IN THE POSITION AND SECURE IT WITH THE WOOD SCREW NO 8 X 1/2".

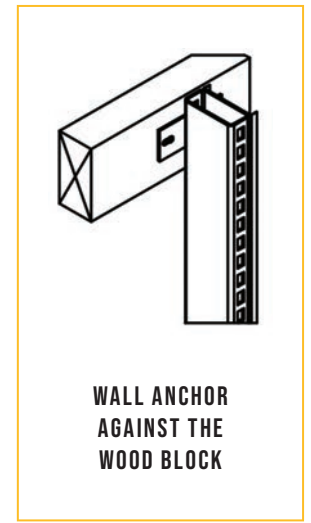
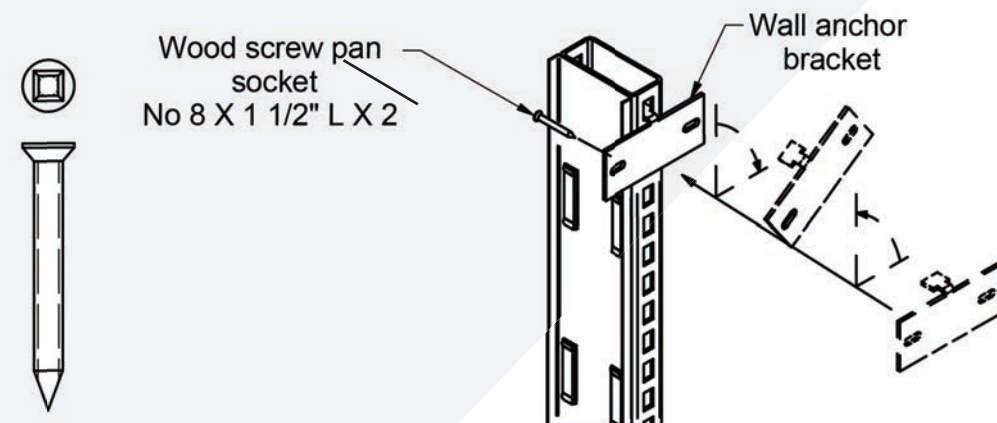

OTHER OPTION: THE WALL ANCHOR BAR IS REQUIRED FOR ALL WALL UNITS, TO LIMIT FORWARD DEFLECTION.

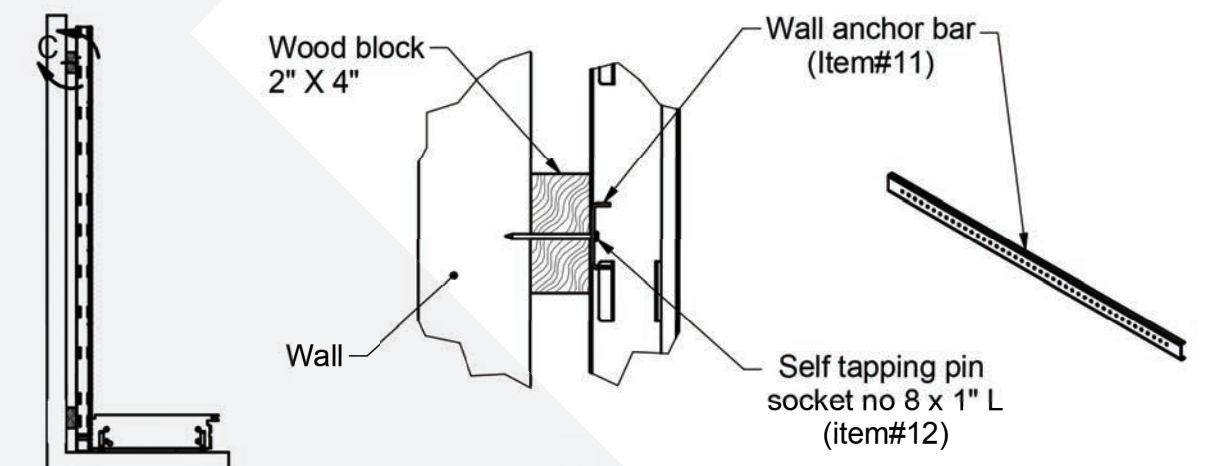

FIXING THE BLOCK TO THE WALL STUDS

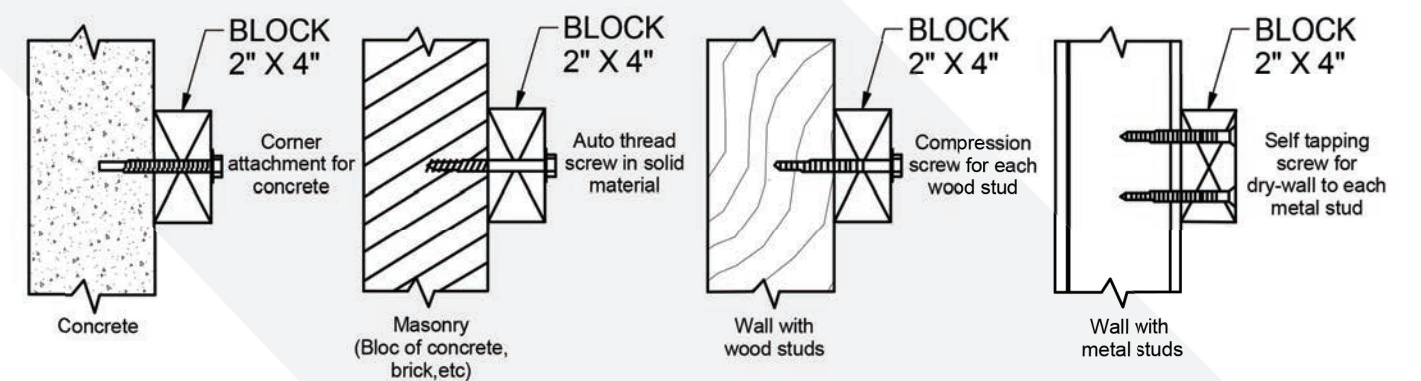

ASSEMBLY

ADJUST THE BASE FOOT LEVELING SCREW AT 3/4" AND THE UPRIGHT POST LEVELING SCREW AT 1/2".

FOOT LOCKING PIN

INSTALL THE BASE SHOE AT THE BOTTOM OF THE POST (UPRIGHT). INSERT THE TEETH INTO THE SLOTS AND APPLY PRESSURE BY PUSHING DOWN THE BASE SHOE UNTIL THE LOCKING PIN IS ENGAGED.

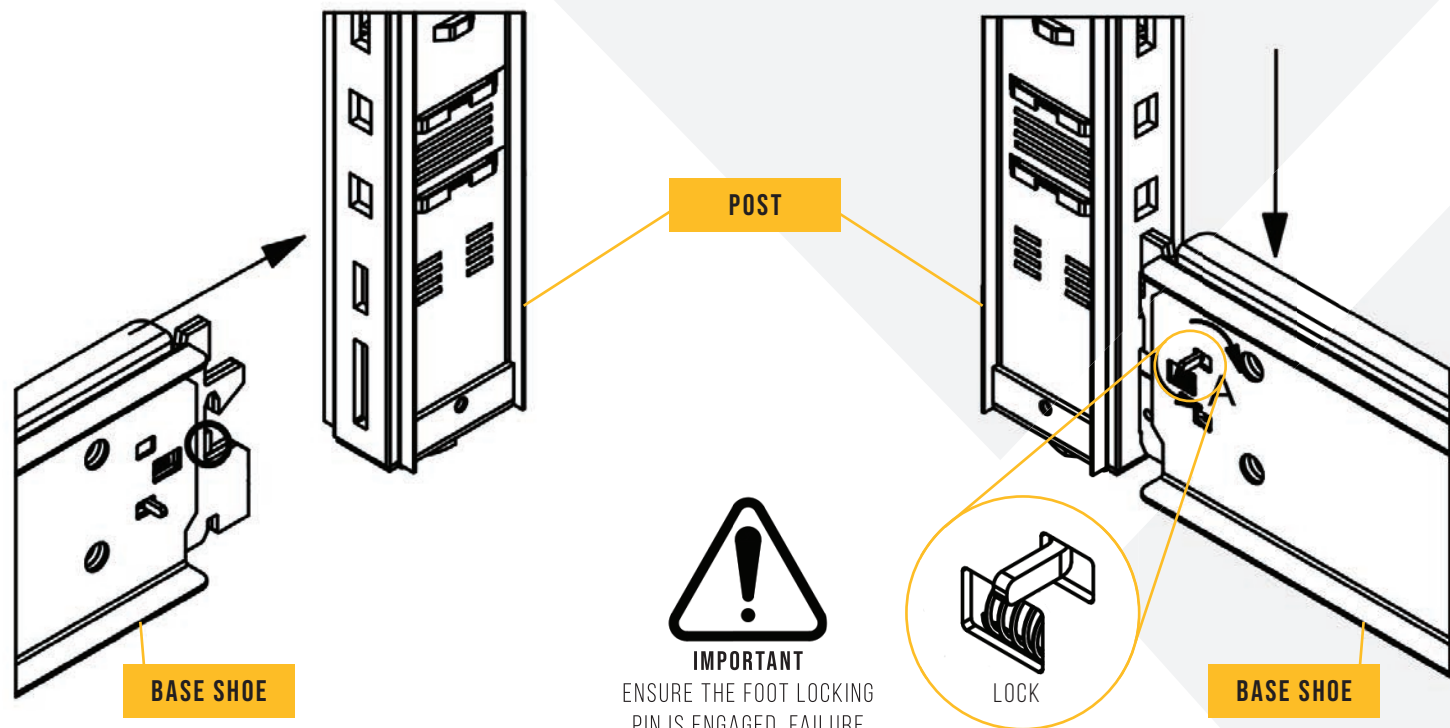

INSTALL THE CROSS-BARS AND THE MASONITE BACKS

- 1- INSERT THE TEETH OF THE BOTTOM CROSS-BAR INTO THE LOWER POSITION OF THE UPRIGHT SLOTS.
- 2- SLIDE IN THE MASONITE BACK AND INSTALL THE INTERMEDIATE CROSS-BAR IN THE MIDDLE REAR OF THE BACK.
- 3- INSTALL THE CENTER CROSS-BAR BEFORE SLIDING THE LAST MASONITE BACK IN PLACE AND INSTALL THE TOP CROSS-BAR .

NOTE:
SLIDE MASONITE BACKS IN PLACE SLOWLY.
DO NOT DROP!

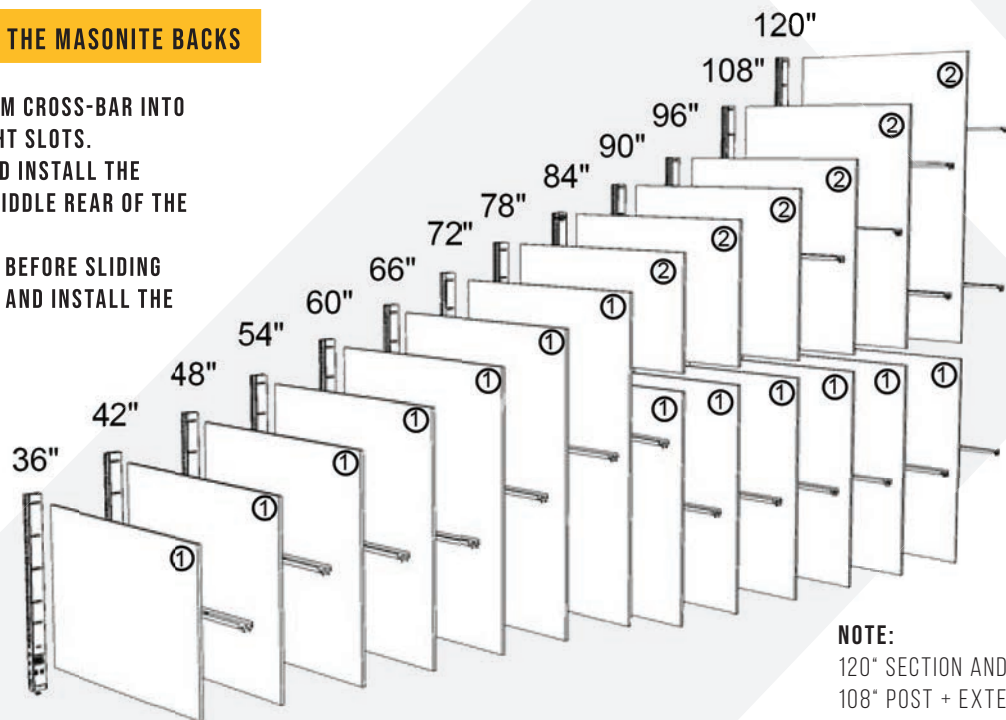

NOTE:
120" SECTION AND +
108" POST + EXTENSION

ASSEMBLY

GRID OF THE MASONITE CHART

POST HEIGHT	FIRST MASONITE HEIGHT	SECOND MASONITE HEIGHT	CENTRAL CROSS-BAR QUANTITY	INTERMEDIATE CROSS-BAR QUANTITY
32"	29 ^{5/8"}	-	-	1
	29 ^{5/8"}	-	-	1
36"	29 ^{5/8"}	-	-	1
	29 ^{5/8"}	-	-	1
	29 ^{5/8"}	-	-	1
42"	35 ^{5/8"}	-	-	1
	35 ^{5/8"}	-	-	1
	41 ^{5/8"}	-	-	1
48"	41 ^{5/8"}	-	-	1
	41 ^{5/8"}	-	-	1
	47 ^{5/8"}	-	-	1
54"	47 ^{5/8"}	-	-	1
	47 ^{5/8"}	-	-	1
	47 ^{5/8"}	-	-	1
60"	53 ^{5/8"}	-	-	1
	53 ^{5/8"}	-	-	1
	53 ^{5/8"}	-	-	1
66"	59 ^{5/8"}	-	-	1
	59 ^{5/8"}	-	-	1
	59 ^{5/8"}	-	-	1
72"	65 ^{5/8"}	-	-	1
	65 ^{5/8"}	-	-	1
	65 ^{5/8"}	-	-	1
78"	23 ^{7/8"}	47 ^{5/8"}	1	1
	23 ^{7/8"}	47 ^{5/8"}	1	1
	23 ^{7/8"}	47 ^{5/8"}	1	1
84"	29 ^{7/8"}	47 ^{5/8"}	1	1
	29 ^{7/8"}	47 ^{5/8"}	1	1
	29 ^{7/8"}	47 ^{5/8"}	1	1
90"	35 ^{7/8"}	47 ^{5/8"}	1	2
	35 ^{7/8"}	47 ^{5/8"}	1	2
	35 ^{7/8"}	47 ^{5/8"}	1	2
96"	41 ^{7/8"}	47 ^{5/8"}	1	2
	41 ^{7/8"}	47 ^{5/8"}	1	2
	41 ^{7/8"}	47 ^{5/8"}	1	2
108"	47 ^{5/8"}	53 ^{7/8"}	1	2
	47 ^{5/8"}	53 ^{7/8"}	1	2
	47 ^{5/8"}	53 ^{7/8"}	1	2
120"	47 ^{5/8"}	65 ^{7/8"}	1	3
	47 ^{5/8"}	65 ^{7/8"}	1	3
	47 ^{5/8"}	65 ^{7/8"}	1	3

ACCESSORIES

ACCESSORIES



ITEM "T" CAP



ITEM STRAIGHT BRACKET
LENGTH 6" - 30"
(IN INCREMENTS OF 2")



ITEM SLOPED BRACKET
LENGTH 10" - 30"
(IN INCREMENTS OF 2")



ITEM FLIP SCAN HOOK
LENGTH 4" - 6" - 8" - 10" - 12"



ITEM SINGLE HOOK
LENGTH 4" - 6" - 8" - 10" - 12"



ITEM SLATWALL HOOK
LENGTH 4" - 6" - 8" - 10" - 12"



ITEM HOOK FOR TUBE
LENGTH 4" - 6" - 8" - 10" - 12"



ITEM WIRE FENCE - 2 1/2" H
LENGTH 24" - 30" - 36" - 48"



ITEM WIRE DIVIDER
LENGTH 6" - 24"
(IN INCREMENTS OF 2")



ITEM SUBDIVIDER
LENGTH 4" - 6"



ITEM WIRE BASKET
(VARIOUS DIMENSIONS)



ITEM CHROME WIRE BASKET (NO ENDS)
LENGTH 10" - 12" - 14" - 16" - 18"
(DEPTH)



ITEM SOFT DRINK SHELF
LENGTH 24" - 30" - 36" - 48"

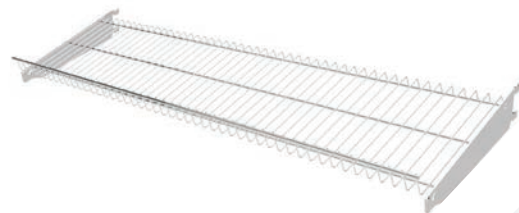

ITEM WIRE SHELF
LENGTH 24" - 30" - 36" - 48"
(LENGTH)

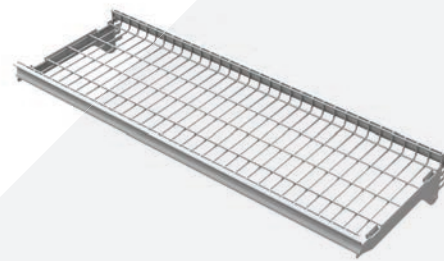

ITEM WIRE SHELF WITH MOLDING
LENGTH 24" - 30" - 36" - 48"



ITEM SHELF WITH SEPARATORS
LENGTH 24" - 30" - 36" - 48"



ITEM ROUND CORNER SHELF
LENGTH 24" - 30" - 36" - 48"

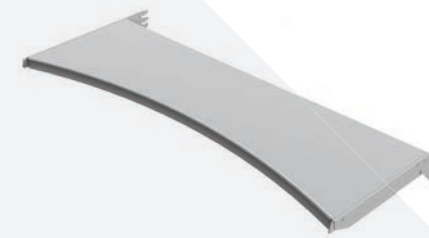

ITEM CONCAVE SHELF
LENGTH 24" - 30" - 36" - 48"



ITEM CONVEXE SHELF
LENGTH 24" - 30" - 36" - 48"

ACCESSORIES

ACCESSORIES



ITEM SIGN HOLDER
FORMAT 24"- 30"- 36"- 48"



ITEM EXTENDED BAR
DEPTH 1"- 4"- 6"- 8"- 10"- 12"



ITEM STRAIGHT CROSSBAR
LENGTH 6"- 8"- 10"- 12"



ITEM 5 BALL CROSSBAR
LENGTH 6"- 8"- 10"- 12"

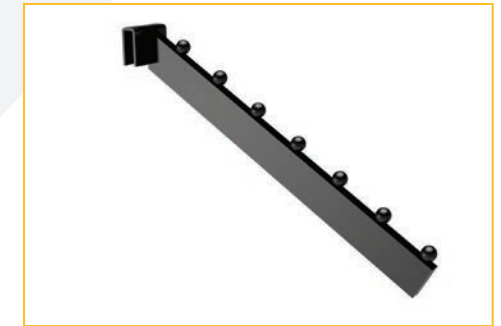

ITEM 7 BALL CROSSBAR
LENGTH 6"- 8"- 10"- 12"

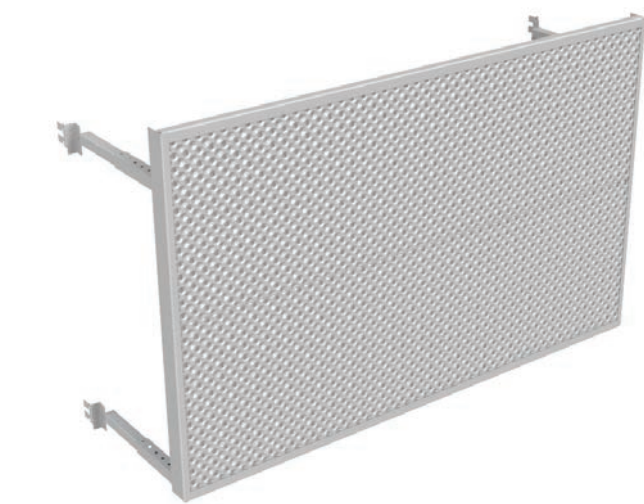

ITEM EXTENDED METAL BACK
WIDTH 24"- 30"- 36"- 48" (VARIOUS HEIGHTS)



ITEM POST EXTENSION
VARIOUS HEIGHTS

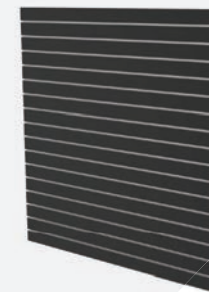

ITEM SLATWALL BACK
WIDTH 24"- 30"- 36"- 48"L X VARIOUS HEIGHTS



ITEM PLAIN BACK (METAL OR MASONITE)
WIDTH 24"- 30"- 36"- 48"L X VARIOUS HEIGHTS

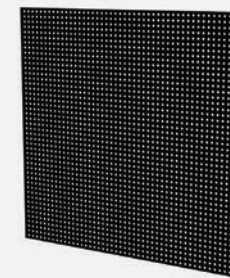

ITEM PERFORATED BACK (METAL OR MASONITE)
WIDTH 24"- 30"- 36"- 48"L X VARIOUS HEIGHTS



ITEM WIRE MESH BACK
WIDTH 24"- 30"- 36"- 48"L X VARIOUS HEIGHTS



ITEM SLOPED SHELF
DEPTH 6"- 8"- 10"- 12"- 14"- 16"- 18"



ITEM SLATWALL SHELF
DEPTH 8"- 10"- 12"



ITEM STRAIGHT METAL SHELF
DEPTH 6"- 8"- 10"- 12"- 14"- 16"- 18"



ITEM "BULLNOSE" METAL SHELF
DEPTH 6"- 8"- 10"- 12"- 14"- 16"- 18"

CONTACT US



Midwest Retail Services, Inc.

800-576-7577

www.midwestretailservices.com

ETALEX™

Member of SJM group

8501, Jarry Street East,

Montreal, QC H1J 1H7

T 514 351-2000

TF 1 800 351-3125

MADE IN CANADA